



Galileo

Galileo is an innovative French company specializing in the design of spherical lightweight concrete vats destined for the sustainable wine industry.

This modern concept owes its original nature to the unique composition of its raw materials and its particular shape, which emphasizes the most natural of phenomena.

G15s

AN INNOVATIVE VAT!

A sphere is the shape that best keeps its contents safe from external environmental influences, as it minimizes the ratio between the external surface and internal volume. This perfect natural shape aims to **preserve convective motion and the energy of the grapes and the wine.**

Galileo vats weigh half as much as traditional concrete containers of the same size, and their original lightweight composition provides **twice as much insulation.**

The Galileo G15s vat, with optimized thermal properties, moderates both external and internal temperature variations taking place during the fermentation process.

Temperature variations are much more gradual than in stainless steel, terracotta, sandstone and traditional concrete vats.

The G15s **does not generally require external energy sources** to control temperature rises or drops during the winemaking and the maturation processes.

Wine finds its natural shape with Galileo!

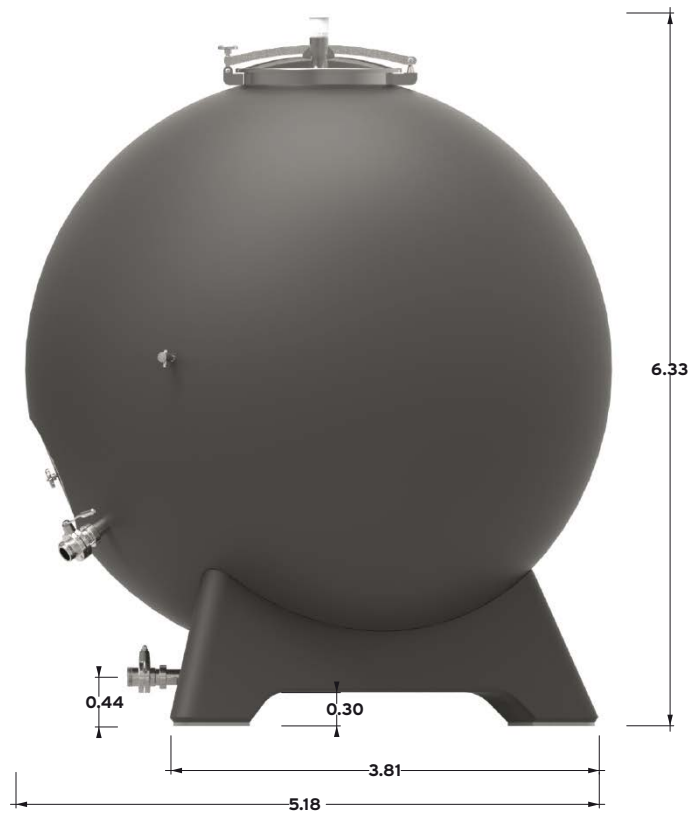

TECHNICAL CHARACTERISTICS

| | |
|------------------------------|----------------|
| Rated capacity: | 400 gal |
| Total height, base included: | 6.33 ft |
| Exterior diameter: | 5.18 ft |
| Approximate thickness: | 3.15 inches |
| Approximate empty weight: | 2640 lbs |
| Approximate full weight: | 5940 lbs |

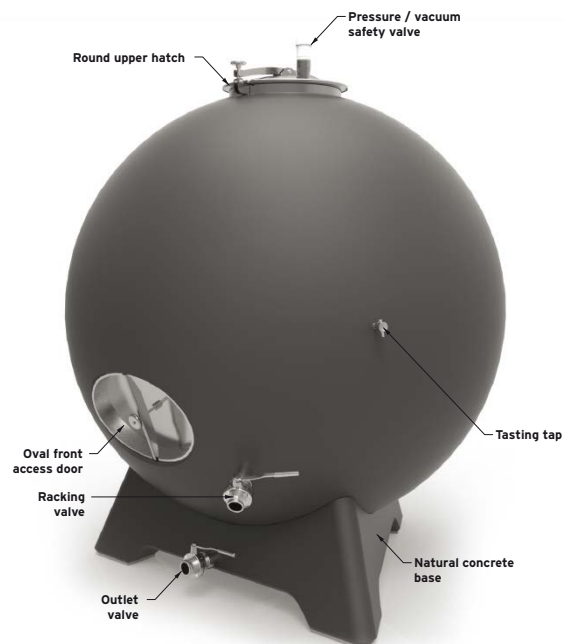

Galileo

AVENUE DE GIMEUX
CS 10225 Merpins
16111 COGNAC CEDEX
info@galileotanks.fr